

T9601

Paging System Transmitter

USER MANUAL

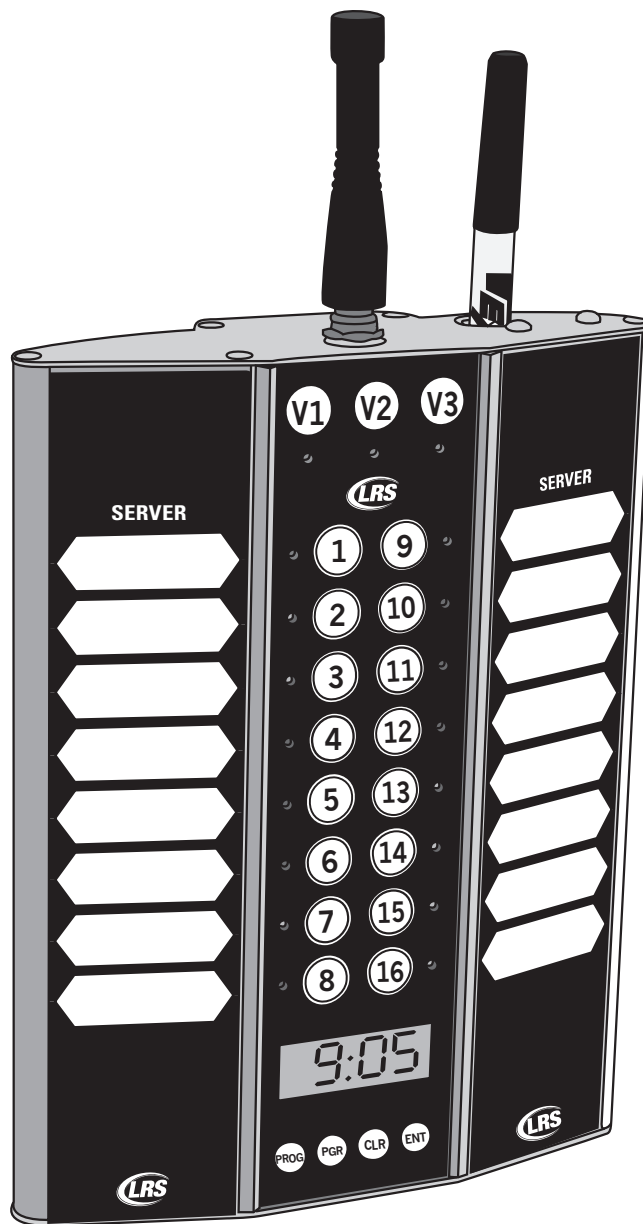

Usage, Installation, Warranty and Service Information

LRS

Long Range Systems, LLC
4550 Excel Parkway, Suite 200
Addison, TX 75001
800.437.4996 • www.pager.net

Warranty

Long Range Systems, LLC permits a one-year manufacturer's warranty following the original consumer purchase date of any LRS system. Any individual components or products purchased will receive a 30-day manufacture warranty. This warranty covers any defects due to faulty material or workmanship, but does not include damage to the product resulting from accident, misuse or improper electrical connection. If the product or system should become defective within the warranty period, we will repair or replace with equivalent equipment, free of charge. We will pay transportation charges to return your product via standard FedEx Ground shipping, provided the product is shipped prepaid to:

**Long Range Systems, LLC
4550 Excel Pkwy, Suite 200
Addison, TX 75001**

No return or replacement can be received without prior authorization from the LRS Customer Support department or without the proper RMA# posted on the outside of the shipping container. Contact Customer Support at 800.437.4996 or www.pager.net. This warranty gives you specific legal rights and you may also have rights that vary by state.

Copyright © 2014, Long Range Systems, LLC All Rights Reserved

This manual contains proprietary information of Long Range Systems, LLC (LRS) and is intended for use only by its employees or customers. None of the material contained herein may be copied, reproduced, republished, downloaded, displayed, posted, or transmitted in any form or by any means, including but not limited to, electronic, mechanical, photocopying, recording, or otherwise without the prior written permission of LRS. Additional copies of this manual may be obtained by contacting LRS.

Screen displays, keyboard layouts, hardware descriptions, or software are proprietary to LRS and are subject to copyright and other intellectual property rights of LRS and shall be treated in accordance with the previous paragraph.

All attempts have been made to make the information in this document complete and accurate. LRS is not responsible for any direct or indirect damages or loss of business resulting from inaccuracies or omissions. Specifications and other information contained within this document are subject to change without notice.

Long Range Systems, LLC. reserves the right to make changes without further notice to any products herein. LRS, LLC makes no warranty, representation or guarantee regarding the suitability of its products for any particular purpose, nor does LRS, LLC assume any liability arising out of the application or use of any product or circuit, and specifically disclaims any and all liability, including without limitation consequential or incidental damages. "Typical" parameters that may be provided in LRS, LLC data sheets and/or specifications can and do vary in different applications and actual performance may vary over time. All operating parameters, including "Typicals", must be validated for each customer application by customer's technical experts. LRS, LLC products are not designed, intended, or authorized for use as components in systems intended to support or sustain life, or for any other application in which the failure of the LRS, LLC product could create a situation where personal injury or death may occur. Should Buyer purchase or use LRS, LLC products for any such unintended or unauthorized application, Buyer shall indemnify and hold LRS, LLC and its officers, employees, subsidiaries, affiliates, and distributors harmless against all claims, costs, damages, and expenses, and reasonable attorney fees arising out of, directly or indirectly, any claim of personal injury or death associated with such unintended or unauthorized use, even if such claim alleges that LRS, LLC was negligent regarding the design or manufacture of the part, device or system.

RF Warning Statement:

1. This device complies with Part 15 of the FCC Rules. Operation is subject to the following two conditions:
 - (1) This device may not cause harmful interference.
 - (2) This device must accept any interference received, including interference that may cause undesired operation.
2. Changes or modifications not expressly approved by the party responsible for compliance could void the user's authority to operate the equipment.

NOTE: This equipment has been tested and found to comply with the limits for a Class B digital device, pursuant to Part 15 of the FCC Rules. These limits are designed to provide reasonable protection against harmful interference in a residential installation.

This equipment generates uses and can radiate radio frequency energy and, if not installed and used in accordance with the instructions, may cause harmful interference to radio communications. However, there is no guarantee that interference will not occur in a particular installation. If this equipment does cause harmful interference to radio or television reception, which can be determined by turning the equipment off and on, the user is encouraged to try to correct the interference by one or more of the following measures:

- Reorient or relocate the receiving antenna.
- Increase the separation between the equipment and receiver.
- Connect the equipment into an outlet on a circuit different from that to which the receiver is connected.
- Consult the dealer or an experienced radio/TV technician for help.

RF exposure statement:

This device must be operated in a stationary table top or wall mount configuration and should not be held or carried while in operation. The user is cautioned to observe a minimum separation distance of at least 1 centimeter from the antenna to user extremities (fingers, hands) and maintain a separation of at least 20 centimeters from the users body.

Table Of Contents

Warranty	1
Long Range Systems	3
General Information	3
Installation and Setup	4
Hardware Provided	4
Installation Procedure	4
Bracket Mounting	7
Keypad Functions	8
Basic Paging Operation Guide	9
Paging	9
Paging a Manager Pager	9
Paging All Call	9
System Settings	10
Setting the Vibration Mode	10
Set the Vibration Strength	10
System Reset	10
Setup All Call	10
Station ID	11
System ID	11
System Reset	11
Set Simulatneous Manager Paging	12
Setup Duty Pager	12
Set Time and Date	13
Set POCSAG Start	14
Set Language	15
Key Tone	15
Maintenance Checks	16
POCSAS Anti-Theft	16
Cleaning the System	16
Programming Pagers	17
Assign Manager Pager	18
System Specifications	18
T9601	18
T9601 Quick Programming Functions Guide	19
Troubleshooting	20
Transmitter Unit	20
Pagers	20
Service Questions and Answers	21
Cleaning & Charging Instructions for LRS Paging Equipment	28
Terms & Conditions	29

Long Range Systems

Long Range Systems is a provider of cutting-edge onsite paging solutions. We offer exceptional products and services that satisfy our customer's needs for years to come. Thorough familiarity with these instructions and procedures will ensure proper operation and maintenance of the system.



NOTE: This guide should be kept readily available for managers and key staff.

General Information

The T9601 is an onsite paging system used to increase efficiency in operations by alerting key staff of immediate needs. The pagers used with the system can vibrate, beep or display LED messaging. The pager-messaging mode is set using the keypad (e.g. vibration).



NOTE: The T9601 only works with LRS Star Pagers, and LRS rechargeable and battery operated alphanumeric pagers (1-line Alpha Pager (SP5), and 4-Line Alpha Pager)

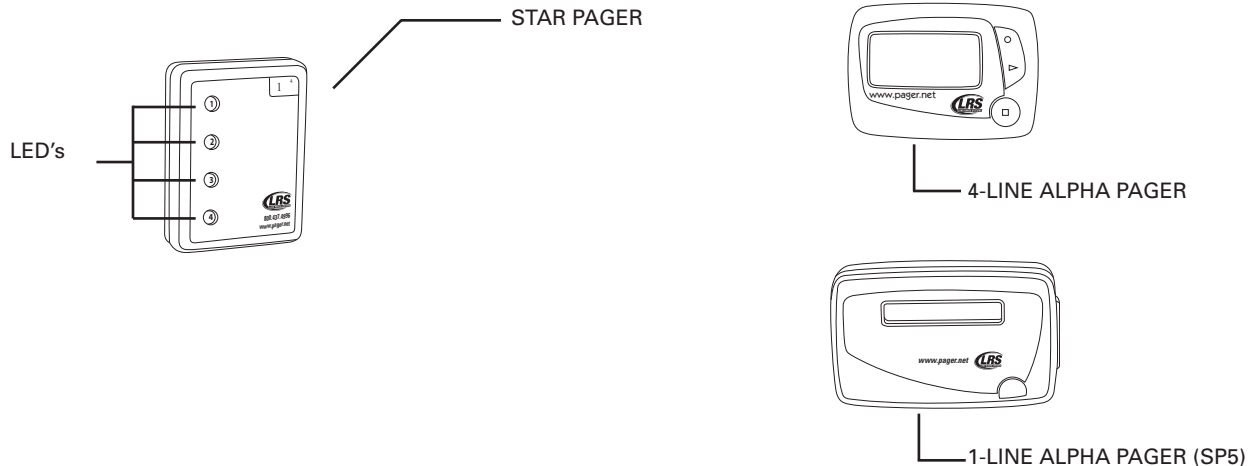

Notice: Operation is subject to the following:

- This device may not cause interference
- This device will accept any interference including interference that may cause undesired operation of the unit.

Basic Installation and Setup

Hardware Provided

Each T9601 transmitter kit contains:

- (1) T9601 Setup Guide
- (1) Transmitter keypad with Dry-Erase name board
- (1) Dry Erase Marker
- (1) Antenna
- (1) 12VDC power adapter
- (1) Thumbscrew
- (1) Thumbscrew Clamp
- (2) Mounting Brackets (1 – with foam pad, 1 – without foam pad)
- (4) Screws

Installation Procedure

The following is the basic installation procedure

CAUTION:

- *The transmitter requires a dedicated power supply*
- *Mounting the antenna near any large metal objects will minimize the operating range.*

1. Unwrap all system components.
2. Twist the antenna into the silver connector located on the top of the transmitter unit.
3. Mount the power supply in a location where there is access to 110V power for charging (see pg. 5 "Mounting Your System")
4. Insert the barrel connector end of the power supply into the connector hole located at the bottom of the transmitter unit
5. Plug the power supply into a standard 110V outlet
6. The LCD screen on the transmitter will light up and display "tin" (time)
7. Press ENT to exit time setup
8. The screen will display a default time 12.00

OR

9. Enter the time hh (hour) mm (minutes) (ex. 10 00), and press ENT
10. Press PGR for AM or ENT for PM
11. The screen will display the time entered ex. 10.00
12. Upon completion of setup, make sure pagers are fully charged use



NOTE: Allow pagers to charge in charging base for at least 24 hours prior to the first use.

Mounting Your System:

Four captive nuts are located in a slider on the backside of the T9601 transmitter. These are used to secure the mounting brackets to the unit. The brackets may be mounted in several configurations dependent upon the mounting surface.

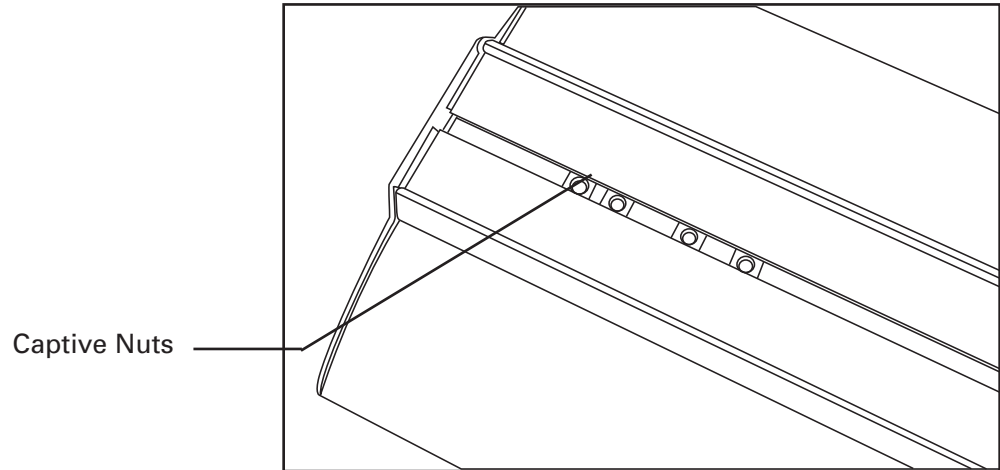

1. Position the non-foam padded mounting bracket so that the side with the two holes (laying flat on the slider) are pointing towards the antenna end of the transmitter.
2. Align the holes with two of the captive nuts.
3. Insert the 2 screws into the holes. Do not fully tighten screws.
4. Repeat steps 1-3 with the foam-padded mounting bracket. The two holes should be pointing opposite the antenna end of the transmitter (foam padding should be facing the opposite bracket).

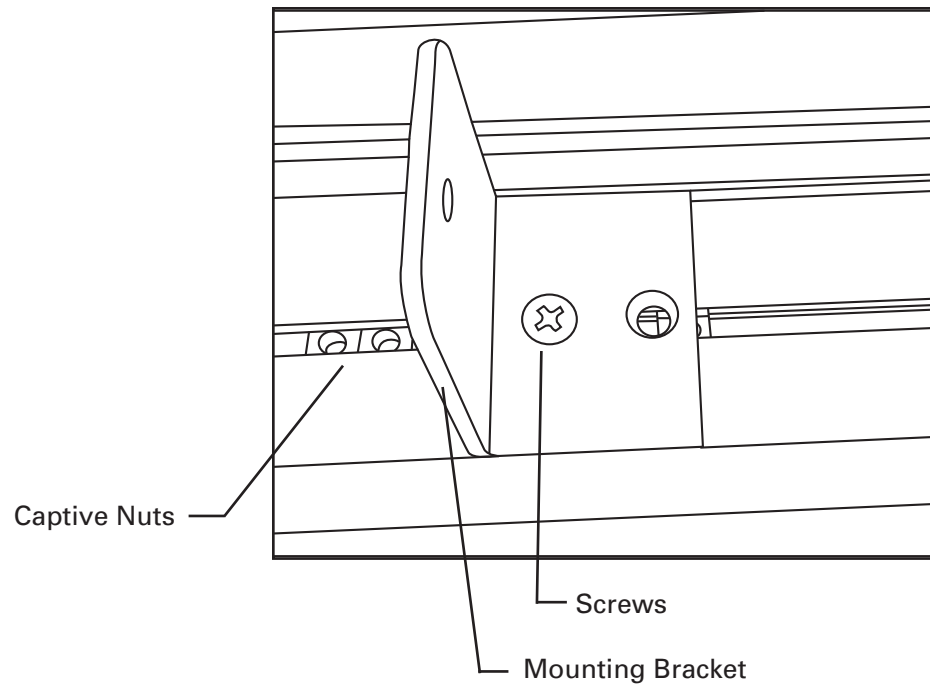

5. Adjust the distance between the brackets to fit the mounting surface.
6. Securely tighten all captive screws.

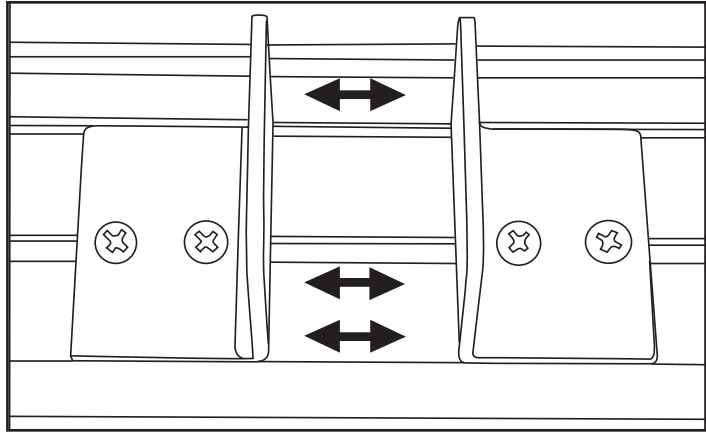

7. In a clockwise motion, turn the thumbscrew into the non-foam padded mounting bracket.
8. Attach and screw the thumbscrew clamp foot to the thumbscrew.
9. Holding the transmitter steady, position the foam padded side of the mounting bracket onto the bottom of the mounting surface.
10. In a clockwise motion, screw the thumbscrew onto the mounting surface, such that the transmitter is positioned firmly onto the surface.

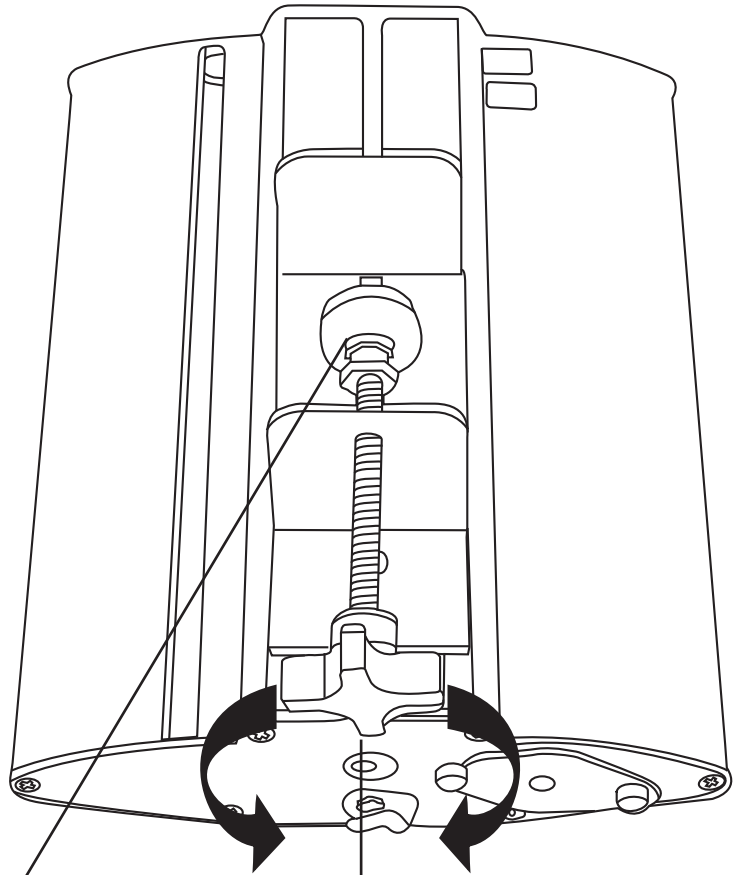

Thumbscrew Clamp Foot

Turn Clockwise to Tighten

Turn Counter-Clockwise to Loosen

Bracket Mounting Suggestions

The basic mounting suggestion is shown here.

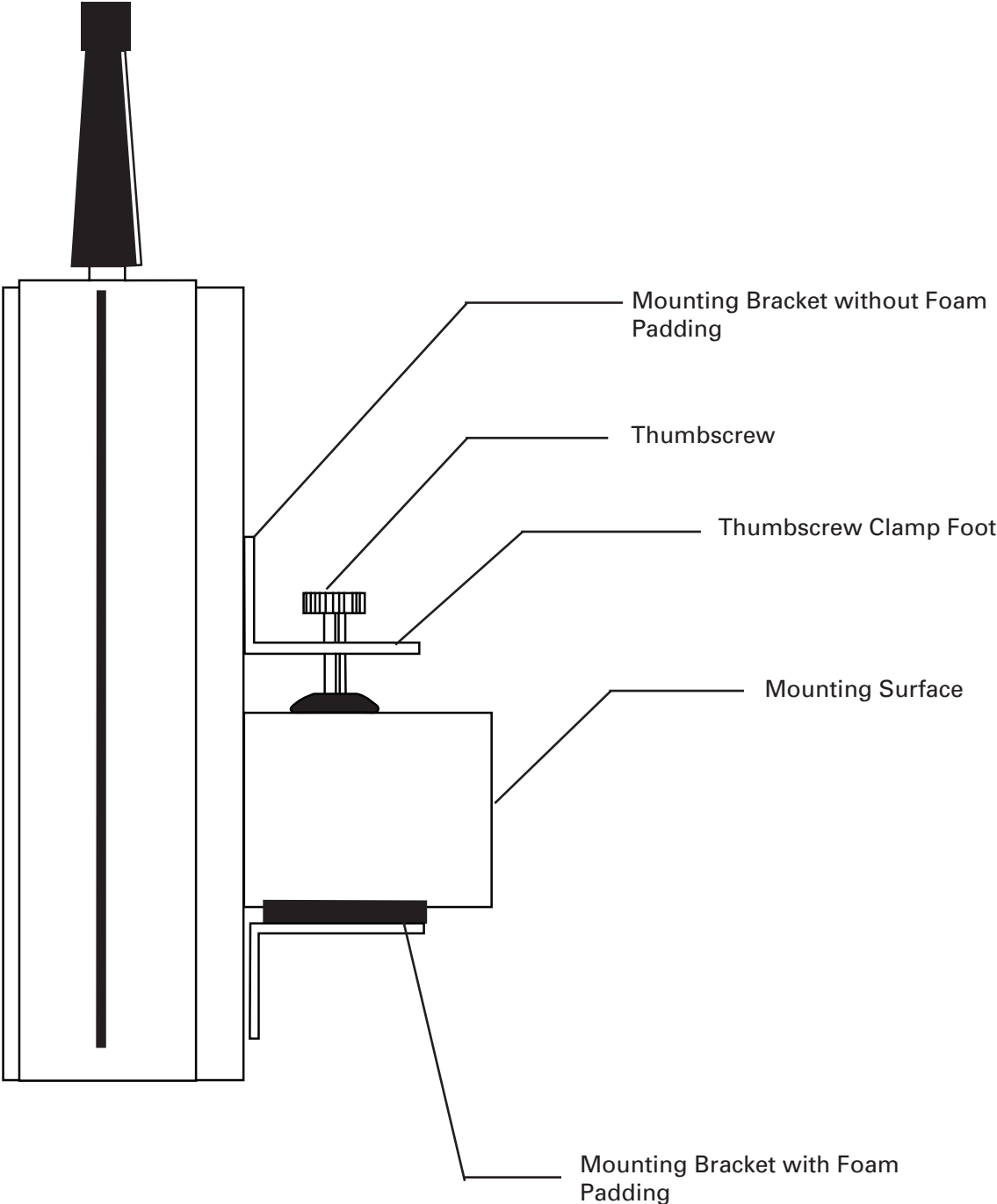

Transmitter/Keypad Elements

Pager Reset Terminals:

Used to reset pagers before reprogramming.

Dry-Erase Server Board:

Write the staff names on the label next to their pager number with a NON-PERMANENT, Dry-Erase Marker or grease pencil.

Keypad Functions

Before using the keypad, read the following key descriptions:

Function Keys:

The function keys are located on the last row of the transmitter keypad.

PROG – Used when altering system settings, functions, and programming pagers

PGR– Used when entering pager numbers above 16

CLR – Used to clear an entry

ENT – Used to enter changes to system settings, functions, and to send a page

Vibration Keys

V1, V2 and V3 select the number of vibrations a pager will respond with. This button is pressed before paging a pager. Sends message 1, 2 or 3 to Alpha pagers.

Number Keys:

Number keys 1 through 16 are “one touch” keys to instantly page pagers 1 – 16. Number 10 is also 0 when programming or paging pagers numbered above 16.

Basic Paging Operations

The T9601 factory defaults are the most commonly used settings (System ID = 0, Vibration Mode = 1).

Paging

For pagers numbered 1 – 16:

1. Press the pager number on the keypad unit
2. The unit will automatically send a page

For pagers numbered 17 and higher:



NOTE: Pagers can be numbered up to 999

1. Press PGR
2. Enter the pager number (using #'s 1 – 9 and 10 [as zero])
3. Press ENT

When a page is sent and received:

- Star Pagers – will flash and vibrate
- Rechargeable and battery operated Alpha Pagers – will display “Kitchen <Station #>” Example: Kitchen 1

Page A Manager Pager

1. Press PGR
2. Enter the manager pager number
3. Press ENT

When manager pager is set and a page is received:

- Rechargeable and battery operated Alpha Pagers – will display “Manager to Kitchen <Station #>”

Example: *Manager to Kitchen 1*

All Call Page

If all pagers need to be called at once,

1. Press PGR
2. Press 0
3. Press the ENT

Alternate Method if “All Call” is enabled (See p. 10 “Set Up All Call”)

1. Press button “16” on transmitter keypad

When All Call Page is enabled and a page is received:

- Star Pagers will flash and vibrate
- Rechargeable and battery operated Alpha Pagers will display “All Page Kitchen <Station #>”

Example: *All Page Kitchen 1*

System Settings

Setting the Vibration Mode



NOTE: The factory default setting for vibration mode is 1 vibration. (EX: When a page is sent from the transmitter, the pager will vibrate once)

To set the vibration mode:

1. Press PROG
2. Enter 9 - 2 - #
 - 1 vibration: # = 1
 - 2 vibrations: # = 2
 - 3 vibrations: # = 3
3. Press ENT

Set the Vibration Strength (Only Applicable to the SP5)

The strength of a pager's vibration when paged can be set.

To adjust the vibration level, between 0 (minimum) and 9 (maximum):

1. Press PROG
2. Enter 9 - 4 - # (# = 0 - 9)
3. Press ENT
 - No vibration: # = 0
 - Mid level vibration: # = 5
 - Maximum vibration: # = 9

System Reset

In certain situations the T9601 may require a system reset before operating properly. When the system is reset, the Restaurant ID (see pg. 11) and vibration mode (see pg. 10) will be set to factory default.

To reset the transmitter to factory default:

1. Press PROG
2. Enter 0-0-0 and press ENTER

Setup All Call

'All Call' sends a page to all pagers at once. When 'All Call' is enabled, pressing the number "16" on the keypad will perform this function.

To enable:

1. Press PROG
2. Enter 9 - 3 - 5
3. Press ENT

To disable:

1. Press PROG
2. Enter 9 - 3 - 4
3. Press ENT

Station ID

When more than one transmitter is being used on the same System ID, a station ID can be set to identify which transmitter the page came from. The station ID will display when a page is sent.

To set:

1. Press PROG
2. Enter 9 - 6 - # (# = Station ID: 1 – 9)
3. Press ENT

System ID

The system ID is used to keep neighboring paging systems from interfering with each other. This setting should only be changes at the advice of an LRS customer support representative.

To change the ID:

1. Press PROG
2. Enter 9 - # - # (# = System ID: 00 – 19) (EX: 9 - 0 - 3, System ID = 3)
3. Press ENT

Set Simultaneous Manager Paging

This feature allows the manager to receive a message anytime a server is paged.



NOTE: This function works with LRS Alpha pagers only.

To turn on:

1. Press PROG
2. Enter 9 - 5 - 1
3. Press ENT

4. LCD screen on transmitter will display On

When a simultaneous manager page is received:

- Rechargeable and battery operated Alpha Pagers – will display “Server #: Kitchen <Station #>”
Example: Server 5: Kitchen 1

To turn off:

1. Press PROG
2. Enter 9 - 5 - 2
3. Press ENT
4. The LCD screen on the transmitter will display Off

Setup Duty Pager

Duty pager is used to remind someone of a task that must be completed at specified intervals. A duty reminder page is sent to the assigned pager at preset time intervals. The system’s “time” must be set prior to enabling duty pager.

To Enable:

1. Press PROG
2. Enter 9 - 8 - 0
3. Press ENT
 - At dut (duty), enter the pager number
 - Press ENT
 - At INT, enter the time (interval) in minutes for the reminder page
 - Press ENT
 - At Str, enter the time of day the task begins: hh (hour) mm (minute) (ex: 10 00)
 - Press ENT
 - Press PGR for A (AM) or ENT for P (PM)
 - At Stp, enter the time of day the task ends: hh (hour) mm (minute) (ex: 12 00)
 - Press ENT
 - Select A (AM) [by pressing PGR] or P (PM) [by pressing ENT]

When duty pager is set and an interval page is received:

- Star Pagers – will flash and vibrate
- Rechargeable and battery operated Alpha Pagers – will display “Reminder Message: Kitchen <Station #>” Example: Reminder Message: Kitchen 1

To Disable:

1. Press PROG
2. Enter 9 - 8 - 0
3. Press ENT
4. At dut (duty), enter “0”
5. Press ENT

Restart Duty Timer

If a task is performed early, the timer can be reset to start the interval over.

To restart:

1. Press PROG
2. Enter 9-8-1
3. Press ENT

Set Time and Date

Time and date are not required for normal use; however, it should be set if duty pager is enabled, and if a time is required for Alpha pagers.



NOTE: Time and date should be reset at each startup

To set time:

1. Press PROG
2. Enter 9 - 3 - 2
3. Press ENT
 - At the tin (time) prompt, enter the hh (hour) and the mm (minute)
 - Press ENT
 - Press PGR for A (AM) or ENT for P (PM)

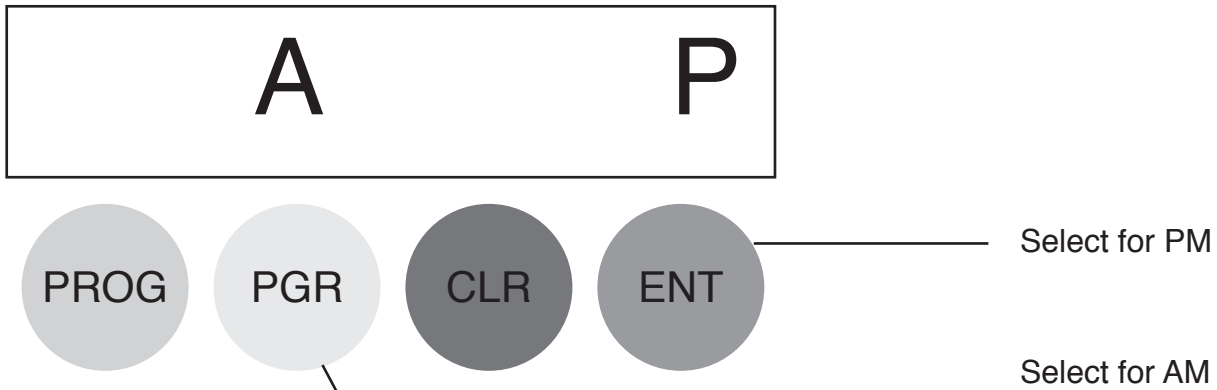

To set date:

1. Press PROG
2. Enter 9 - 3 - 3
3. Press ENT
 - At the (month) prompt, type the mm (month)
 - Press ENT

 - At the (day) prompt, type the dd (day)
 - Press ENT

- At the (year) prompt, type the yy (year)
- Press ENT.

Send Time and Date to Alpha pagers

The T9601 automatically sends the date and time every minute. However, you can also manually send time/date to all Alpha pagers using the transmitter keypad.

To send time/date:

1. Press PROG
2. Enter 9 - 3 - 1
3. Press ENT

Set POCSAG Start

In systems using both Alpha pagers and Star pagers, a start for the POCSAG (alpha) pagers must be set. The default POCSAG start for alpha pagers is 50. Alpha pagers should be programmed using a number equal to or above 50. Star (SP4) pagers should be programmed using a number below 50.

To setup:

1. Press PROG
2. Enter 8 - # - # (# is a number between 01 and 99)
3. Press ENT

Set Language

The T9601 provides the option to transmit preset messages to alphanumeric pagers in different languages. The following languages are available: English, Spanish, French, German, Italian, and Portuguese.

To set a language:

English (default)

1. Press PROG
2. Enter 9 - 5 - #
3. Press ENT

- English: # = 3
- Spanish: # = 4
- French: # = 5
- German: # = 6
- Italian: # = 7
- Portuguese: # = 8

Key Tone

The default key tone for the T9601 is a 'beep' sound when keypad buttons are pressed. However, the key tone 'beep' sound can be disabled.

To enable:

1. Press PROG
2. Enter 9 - 8 - 6
3. Press ENT

To disable:

1. Press PROG
2. Enter 9 - 8 - 7
3. Press ENT

Maintenance Checks

Range Test

Perform a range test to determine the effective range of the T9601.



NOTE: Be sure to remove pagers from the charging base before performing the range test.

1. Press PROG - 9 - 9 - 7 - ENT
2. The screen will display "tst" and then a "-" (dash) will appear
3. When the "-" (dash) begins scrolling across the screen, pagers will vibrate every 5 seconds (as long as they are receiving the signal)
4. Take a pager and walk around the area to verify the pager operates in all areas (the pager will stop vibrating when it is out of range)
5. Press ENT To stop the range test

Anti-Theft

Anti-theft is used to alert staff carrying alpha pagers that they are leaving the premises while still carrying the pager.



NOTE: Anti-Theft only works with alphanumeric pagers.

To Turn On:

1. Press PROG
2. Enter 9 - 9 - 9
3. Press ENT

To Turn Off:

1. Press PROG
2. Enter 9 - 9 - 8
3. Press ENT

When Activated:

- The transmitter sends a signal to alpha pagers, and if the signal is not received, the pager will emit a continuous beep sound until it is returned to the charging unit or is back within range.
- The LED screen on the alphanumeric pagers will display "OUT OF RANGE".

Cleaning The System

Caution: *Do not use any cleaning solutions containing chloride*

When cleaning the T9601 system and its components (pagers, charging base), DO NOT use any cleaning products that contain Chloride. These products will damage the material and will stain the surface.



NOTE: Be sure to unplug the T9601 system and charging base before cleaning.

To Clean:

- Using a damp cloth, wipe the exterior of the system's components

Programming Pagers

If a new pager number needs to be assigned to a pager, Star (SP5) and Alpha pagers can be reprogrammed from the T9601 transmitter. If you would like to assign or reassign numbers to pagers, contact LRS to verify your restaurant ID before proceeding.

To Program Pagers:

1. Be sure the POCSAG start is correct for programming pager types (see "Set POCSAG Start" pg. 14)
2. Pagers:
 - Remove rechargeable pagers from the charger (or reset by touching the silver nodes on the pager to the reset terminal on the transmitter) and wait until it stops vibrating
 - Turn battery powered pagers on and then off (or remove and reinstall the battery) and wait until it stops vibrating and/or beeping
4. Press PROG
5. Enter the number you wish to assign to the pager (Choose #: 1 - 999)
6. Press PROG
 - Star pagers will slowly vibrate and light up then dim to off
 - Alpha pagers will beep 4 times and then stop
7. Once programming is complete, page the pager to ensure it is programmed correctly
(See "Basic Paging Operations" p. 9)

Top View of the T9601

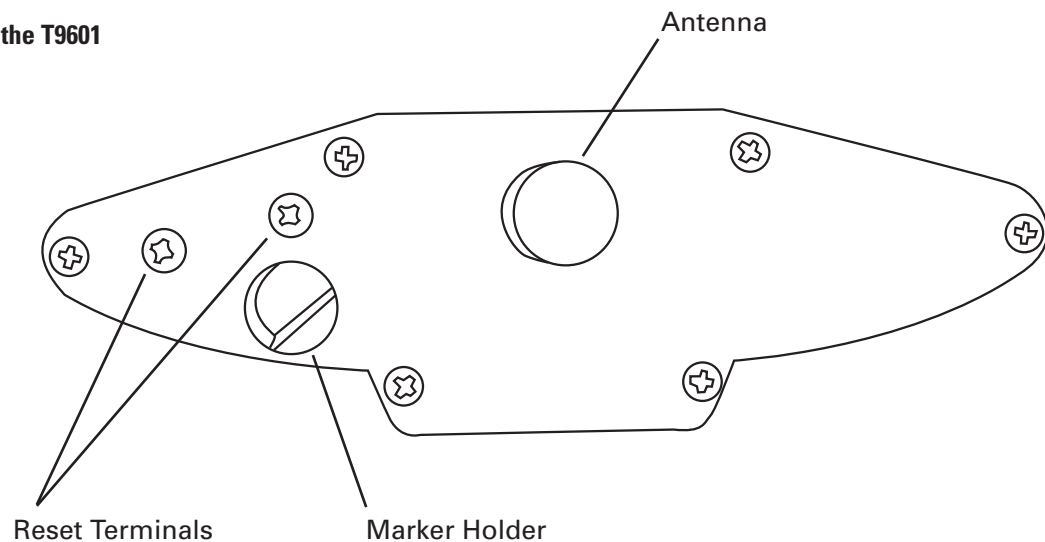

Assign Manager Pager

A manager pager can be assigned to notify a manager what station they are needed at when a page is received. Only LRS alphanumeric pagers (rechargeable and battery operated) can be set as manager pagers.

Set Manager Pager

1. Press PROG
2. Enter 9 - 8 - 5
3. Press ENT
4. At Ngr (manager), enter the pager number
5. Press ENT



NOTE: Manager pager cannot be disabled. However, you can reassign manager pager to a different pager number. To reassign, follow the steps for setting manager pager and enter a different pager number.

System Specifications

Notice: Operation is subject to the following:

- This device may not cause interference.
- This device will accept any interference including interference that may cause undesired operation of the unit.

T9601

Required Voltage: One-110V outlet for the T9601 transmitter

(Batteries: This option currently NOT available)

Operating Frequency: 467.750MHz

Radiated Power: <4900 micro-volts/meter

Operating Range: Dependent upon the paging environment

T9601 Quick Programming Functions Guide

When programming functions:

1. Press PROG
2. Enter the Function Code
3. Press ENT

Function	Function Code	Notes
Reset	0	System settings default to: Station ID = 1 System ID = 0
Vibration 1, 2, or 3	9 2 #	# = Vibration = 1, 2, or 3
POCSAG Start	8 # #	## = Start = 01 – 99
System ID (Restaurant ID)	9 # #	## = ID = 00 – 19
Time: Send to Pager	9 3 1	Sends Time and Date to Alpha Pagers
Set Time	9 3 2	At TIM enter hh mm (Hour, Minute) Press ENT Press A or P (AM/PM)
Set Date	9 3 3	At DTE enter mm (Month), press ENT dd (Day), press ENT yy (Year), press ENT
Setup All Call	9 3 #	# = 5 = ON # = 4 = OFF
Vibration Strength	9 4 #	(# = 1 – 9) # = 0 = OFF # = 1 = Minimum # = 9 = Maximum
Simultaneous Manager Paging	9 5 #	# = 1 = ON # = 2 = OFF
Language	9 5 #	# = Language • English = 3 • Spanish = 4 • French = 5 • German = 6 • Italian = 7 • Portuguese = 8
Station ID	9 6 #	# = ID = 1 – 9
Firmware Version	9 7 5	
Duty Pager Setup	9 8 0	At dut , enter pager #, and press ENT(Pager # = 0 disables) At Int, enter interval time and press ENT At Str, enter start time and press ENT At Stp, enter stop time and press ENT
Duty pager Reset	9 8 1	Restarts interval timer on duty pager
Manager Pager	9 8 5	At Mgr, enter the pager number Press ENT
Enable/Disable Key Tone Beep	9 8 #	# = 6 = ON # = 7 = OFF
Enable/Disable AM paging	9 9 #	# = 1 = ON # = 0 = OFF
Range Test	9 9 7	Enables Range Test (Press ENT to stop)
POCSAG anti theft ON/OFF	9 9 #	# = 9 = ON # = 8 = OFF
All Call Paging	Press PGR	Enter "0" and Press ENT
One Touch Paging	Press the pager #	Pager #'s (1 – 16)
High Number Paging	Press PGR	Enter pager # (1-999) and Press ENT
*Programming Pagers	Press PROG	Enter pager # (1-999) and Press PROG

* Make sure POCSAG Start is set

Transmitter Unit

The Light On The Keypad Display Does Not Come On When A Key Is Pressed

- Check the charging power supply by plugging the power/charging supply used for the pager charger into the transmitter unit.
- If the display light comes on, there may be a problem with the T9601 power/charging supply. Call LRS Customer Support to order a new power supply.
- If the display still does not light, there may be a problem with the transmitter unit. Call LRS Customer Support for assistance.

The Keypad Display Is Functioning Properly But The Pager Does Not Receive the Page

- Perform a system reset (see "System Reset" pg. 10).
- Make sure that pagers are on the same system ID (see "Set System ID" if ID is not "0")
- Complete the steps for paging a pager (see "Paging" pg. 9).
- If the pager still does not receive the page, call LRS Customer Support for assistance.

Pagers

Pager Charge Lights Do Not Come On

Charging slots should display a single red charge light when pagers are placed in the charger, and are charging correctly. If the red charge light is not visible on some or all charging slots, review the following recommendations to determine and solve the problem..

- Make sure the pagers are completely inserted into the charging slot.
- The power supply may be defective. Try plugging the power supply used for the transmitter into the pager charger.
- You might have more pagers charging on one power supply than recommended. Only 25 pagers can be charged on one 12V power supply. If you have more than 25 pagers, you should call LRS to order additional chargers.
- You might have a jumper wire that is not properly connected. Look on the side of your charger and verify that all wires are connected properly. If they are connected, then the metal contacts on your pager may be dirty. Using a damp rag, clean the 2 metal contacts on the back of each pager.
- Be sure that your staff is not disconnecting the power supply at anytime or that you do not have the charger connected to a circuit that automatically shuts off after hours. The charging base should be plugged into a power outlet that is "ON" at all times (Be sure the pager is not in the charger backwards).
- If none of these recommendations solve your problem, call LRS Customer Support to determine the problem at 800-437-4996.

Battery Powered Pager Shows Low Battery:

Replace the battery.

Service Questions and Answers

Should your paging system ever fail or should you need additional paging equipment, call Long Range Systems at (800) 437-4996.

Normal Business Hours

Monday – Friday 8:30 am to 5:00 pm Central Time.

Weekend or Evening Emergencies:

- Long Range Systems provides 24/7 live technical support.
- Please keep in mind that replacement options are limited on weekends and holidays.

LRS PAGERS AVAILABLE FOR THE T9601

(These pagers are sold separately)

- SP5 Rechargeable Alpha
- LRS 4-Line Alpha
- Star Rechargeable Pager

LRS Pagers Available for the T9601

Using the SP5 1-Line Rechargeable Alpha Numeric Pager

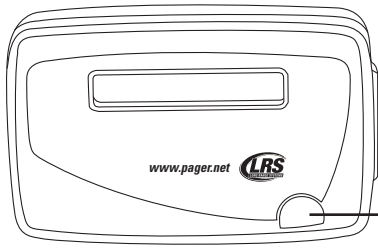

Select Button

Charging

Any rechargeable pager will require the use of an LRS charger. The SP5 uses the Charger 5 (CH-R5).

1. Place the pager in the charger
2. Allow unit to charge fully overnight (at least 24 hours)
3. Remove from charger and the pager will vibrate or beep
4. The LCD will show:
 - C1: [System ID] Pager ID (Ex. C1: [0] 91)
 - Programming Active
 - Blank screen or Date and Time (if set) (Ex. 10/07/2008 12:05 am)
5. Return the pager to the charger at the end of each day

Menus

To access the vibe/contrast menu:

1. Remove the pager from the charger.
2. While vibrating or beeping, press and hold the Select button for 8 seconds.

The menu will display:



3. If you PRESS and RELEASE the Select Button, the menu selector will scroll to the right and will highlight "Contrast"



4. To exit this menu wait 8 seconds
5. To re-enter the vibe/contrast menu at anytime, repeat Step 1

Vibe

To set the Vibration Level:

1. Remove the pager from the charger
2. While vibrating or beeping, press and hold the Select Button for 5-8 seconds

3. Highlight the Vibe selection then PRESS and HOLD the Select Button until the screen shows.



4. Press or hold the Select Button until the desired vibration level is selected
5. If holding down on the Select Button, the vibe level will increase to max and then decrease towards the minimum
6. Release the Select Button when desired vibration level has been reached
7. To exit, wait 8 seconds and the pager will go back to the vibe/contrast menu



Contrast

To set the Contrast Level

1. Remove the pager from the charger
2. While vibrating or beeping, press and hold the Select Button for 5-8 seconds
3. Highlight the Contrast selection then PRESS and HOLD the Select Button until the screen shows.



4. Press or hold the Select Button until the desired contrast is selected
5. If holding down on the Select Button, the contrast level will increase to Max (NOTE: screen could be dark and hard to read)
6. Release the Select Button and press or hold again to change the level back towards the minimum or until your desired contrast is selected
7. To exit, wait 8 seconds and the pager will go back to the vibe/contrast menu



8. To exit this menu wait 8 additional seconds

Settings

To view the current pager settings

1. Remove pager from the charger or reset on the T9601 reset terminals.
2. Press the Select Button repeatedly to scroll through the settings:
 - C1: [System ID number] and Pager ID number
 - C2: [System ID number] and All Page number
 - C3: [System ID number] and System ID number
 - G: Group number
 - Enc: Encryption enabled (128) or none
 - Ver: Current Firmware Version
3. To exit, wait 8 seconds.

Messages

The pager stores the last 5 received messages.

To view the messages:

1. At the (blank screen/time & date) menu display, press the Select Button once
2. Messages 2 lines in length will show a > symbol at the end of the first line and a < symbol at the beginning of the second line
3. Messages over 2 lines in length, the middle lines will show "< the next line of the message >"
4. Press the Select Button to continue scrolling forward through the message or messages

Time

The SP5 pager will display the current time. The T9601 transmitter automatically updates this feature. If the time does not appear, a flashing star will appear on the right side of LCD to show the pager is operational.

- To send time information to the pager from the transmitter, see "Send Date/Time" pg. 13

Programming

To reset and reprogram the pager, see "Programming Pagers" p. 17 of this document.

Using the 4-Line Alpha Numeric Pager

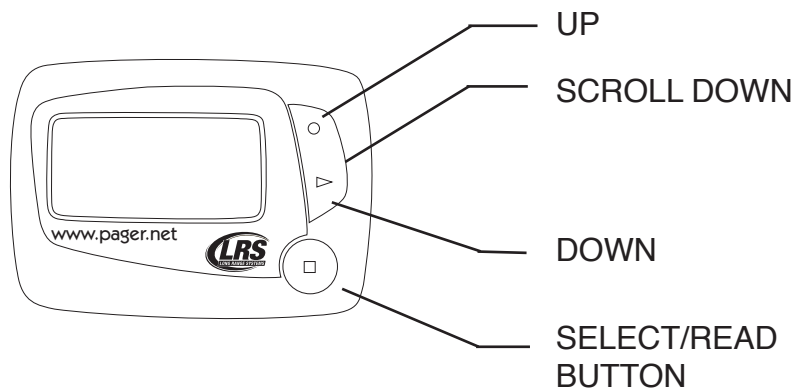

Menus

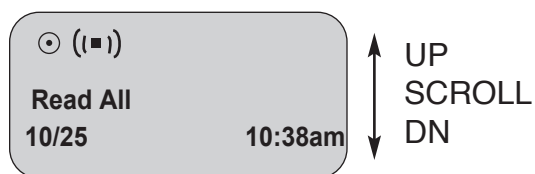

Selecting functions

1. From Read All screen, press Up (or Dn) Scroll button until desired selection displays
2. Press Read/Select button to select item
3. Press Up (or Dn) Scroll button to choose/adjust
4. Press Read/Select to confirm/set

Power On/Off

Set ON (if unit is off)

1. Press and hold Scroll Up until YES/NO shows.
2. At "Power ON?" use Up (or Dn) Scroll button to select **YES**
3. Press Read/Select button to set

Set OFF

1. Using the Up (or Dn) scroll button scroll until display shows "Power OFF?"
2. Press Read/Select button to set power on/off
3. At "Power OFF?" screen, use Up (or Dn) Scroll button to select **YES**
4. Press Read/Select button to set

Read Message

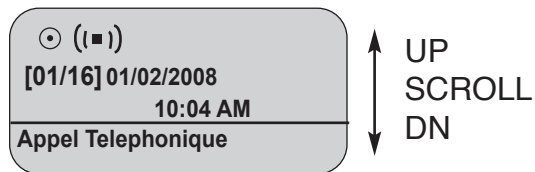

- Messages are displayed upon receipt.
- Press Read/Select to display.

To review stored messages:

1. Select "Read All?"
2. Press Read/Select to display messages and time stamps
3. Use the Up (or Dn) Scroll button to scroll through messages

Delete Messages

1. Using the Up (or Dn) scroll button, scroll until display shows "Delete All?"
2. Press Read/Select
3. Use the Up (or Dn) scroll button to select **Yes** or **No**
4. Press Read/Select button to confirm

Time/Date Set

1. Using the Up (or Dn) scroll button scroll until display shows "Set Time/Date"
2. Press Read/Select to set time/date
3. Press Up (or Dn) scroll button to set each time or date segment and press Read/Select to move through the segments

Set Contrast

1. Using the Up (or Dn) scroll button scroll until display shows "Set Contrast"
2. Press Read/Select
3. Use the Up (or Dn) scroll button to adjust
4. Press Read/Select to confirm

Auto ON/OFF

1. Using the Up (or Dn) scroll button scroll until display shows "Auto ON/OFF"
2. Press Read/Select to set auto on/off
3. Use the Up (or Dn) scroll button to select **On** or **Off**
4. Press Up (or Dn) scroll button to set on/off time and press Read/Select to move through the segments

Set Key Tone On/Off

1. Using the Up (or Dn) scroll button scroll until display shows "Set Key Tone"
2. Press Read/Select to set key tone on/off
3. Use the Up (or Dn) scroll button to select **On** or **Off**
4. Press Read/Select to set

Select Alert Mode

1. Using the Up (or Dn) scroll button scroll until display shows "Set Alert Mode"
2. Use the Up (or Dn) scroll button to select Beep/Vibe Off
3. Press Read/Select to set:

Beep - Use the Up (or Dn) scroll button to select:

- Select Loud or Soft and press Read/Select to set
- Select Duration (seconds) and press Read/Select to set

Vibe Off - Use the Up (or Dn) scroll button to select

- Press Read/Select to set

Battery

The RX-E 4-Line Alpha pager uses 1 AAA Battery.

Programming

To program the pager see pg. 17

Using the Star Pager



Charging

Any rechargeable pager will require use of an LRS charger. The Star Pager (SP4) uses the Charger 9 (CH-R9).

1. Place the pager in the charger
2. Allow unit to charge fully overnight (at least 24 hours)
3. Remove from charger, and pager will vibrate, beep, and light
4. Replace the pager in the charger at the end of each day

Messages

The pager can vibrate, beep, and light up message lights.

Vibration

- Star Pagers will vibrate a certain number of times depending on the vibrate mode - V1, V2 or V3 that is selected from the transmitter keypad when sending a page
- Vibrations can be used to send additional information or to identify 1 of 3 stations
- By sending messages using vibrations, the person being paged will not have to look down to see the lights display, instead the vibrations will let them know what station the page came from

Example: V1 = Station 1, V2 = Station 2, V3 = Station 3

To set vibration – see p.10

LED Messaging

- The LED lights located on the front of the Star pager can be used to represent Station ID's in locations where more than one T9601 transmitter is being used
- Each T9601 transmitter in use represents a "Station ID"
- When a page is sent, the LED lights, letting staff know which transmitter (Station ID) the page came from

Example:

- LED 1 lights = Station 1
- LED 2 lights = Station 2
- LED 1 & 4 light = Station 5

To set LED messaging – see p.11

Programming

To program the Star Pager, see page 17.

Cleaning & Charging Instructions For LRS Paging Equipment

Cleaning:

LRS pagers are made from industrial-strength, polycarbonate material. However, this material is susceptible to hairline cracking if non-approved cleaners are used. When cleaning LRS pagers, we recommend only using ISOPROPYL ALCOHOL-BASED CLEANERS.

To clean the equipment:

1. Take a clean rag and an isopropyl-alcohol based cleaner
2. Soak the clean rag with the isopropyl alcohol cleaner
3. Wipe down the pagers or equipment.

Cleaning equipment with any other non-approved cleaners can weaken plastic and cause hairline cracks. Pagers and equipment that are cleaned with unapproved cleaners and suffer cracking will not be covered under warranty.

Do not submerge any LRS paging equipment in any type of liquid as this will also damage the equipment and is not covered under the standard warranty.

Charging:

Place rechargeable pagers on the charger and let them charge for 8 hours prior to first use.

Rechargeable pagers should be kept on charge even during extremely long periods of inactivity.

Only 12 VDC power supplies should be used with LRS chargers and transmitters. DC power supplies will cause damage to equipment that is not covered under the standard warranty.

Should you have any questions, please contact the LRS Customer Service Department at 800.437.4996.

Terms & Conditions

GENERAL TERMS AND CONDITIONS FOR LONG RANGE SYSTEMS, LLC (FOR PURCHASERS)

These general terms and conditions (“General Terms and Conditions”) govern all persons (“Purchasers”) that purchase or license equipment, software, firmware, and/or services (collectively “Deliverables”) from Long Range Systems, LLC (“LRS”).

Limited Software Use License. All software and firmware (collectively “Software”) is licensed for use only by Purchaser and, in the case of Software for paging receivers, by customers of Purchasers. The Software is not sold.

Usage Restriction. Paging technology may at times not work due to structural and other types of interference with signal transmission and due to other reasons. Purchaser therefore agrees not to use any Deliverable for an application in which a paging failure might cause harm to a person, injury to a property, or a substantial business loss. Purchaser also agrees to abide by and strictly adhere to any rules, regulations and guidelines related to the use of any portion of any Deliverable to collect, store or transmit personally-identifiable information, including any “protected health information” (as defined by HIPAA), or billing or financial payment data, from any customer or other consumer.

Data Collection. In connection with the Deliverables, data provided by Purchaser and its customers may be collected in connection with surveys, consultations, and uses of the Deliverables, including email addresses, telephone numbers, locations of users (which may utilize geo-location technology), times of usage, times of paging, times of responses to paging, devices used, configuration preferences, cookies, and social network information. In order to provide LRS’s customers with enhanced comparative benchmarking services with respect to customer industries, among other services, Purchaser hereby grants to LRS a royalty-free, perpetual, irrevocable license to use and distribute this data and results obtained through Purchaser’s use of the Deliverables for any and all purposes; provided that LRS shall not identify any Purchaser, or distribute to third parties any “protected health information” (as defined by HIPAA) or billing or financial payment data of any customer or consumer of Purchaser, without the express prior consent of such Purchaser. Purchaser warrants that Purchaser has the right to disclose, transfer or otherwise make available any Protected Health Information (as defined in 45 C.F.R. § 160.103) or other personally identifiable information that is made available to LRS by Purchaser or by Purchaser’s customers in connection with the Software or other Deliverables. Without limiting the foregoing, Purchaser shall obtain all authorizations, consents or other permissions from Purchaser’s customers (or the customer’s authorized personal representative) for the disclosure of customers’ personally identifiable information to LRS that are required by federal, state or local law, including, without limitation, the administrative simplification section of the Health Insurance Portability and Accountability Act of 1996 and its implementing regulations.

Limited Warranty. LRS warrants to only Purchaser that the Deliverables will perform in accordance with specifications for them that LRS has published prior to their delivery for a period of time as specified in the purchase agreement or purchase order relating to such Deliverables. This limited warranty shall be voided if any Deliverable is modified or serviced by someone other than LRS.

Disclaimers. LRS HEREBY DISCLAIMS ALL IMPLIED WARRANTIES CONCERNING THE DELIVERABLES, INCLUDING ANY IMPLIED WARRANTY OF MERCHANTABILITY, ANY IMPLIED WARRANTY OF FITNESS FOR A PARTICULAR PURPOSE, OR ANY IMPLIED WARRANTY OF NON-INFRINGEMENT. PURCHASER ACCEPTS THE DELIVERABLES “AS IS,” EXCEPT FOR THE EXPRESS LIMITED WARRANTY MADE HEREIN.

Limitation of Remedies. In the event of any breach of any express warranty made herein, LRS may at its option repair or replace any defective Deliverable or refund the money that Purchaser paid for it. LRS's total liability for any defect in any Deliverable or for any other breach of any of its duties and obligations to Purchaser shall be limited to the amount of money that was paid for the defective Deliverable or the other duty or obligation. LRS will in no event be liable for any lost profit or any other type of consequential damage.

Confidentiality. The Deliverables and all computer systems that deliver any portion of them contain confidential trade secret information. Purchaser shall not attempt to reverse engineer any portion of the Deliverables or such computer systems, such as to decompile any portion of the Software, nor aid anyone else in doing so.

Intellectual Property. No portion of any intellectual property right in the Deliverables is being transferred to the Purchaser or to its customers. Purchaser may not copy or modify any portion of the Deliverables, nor permit or aid anyone else in doing so. Notwithstanding, Purchaser may use the Deliverables as they are intended to be used, as expressed in written materials published by LRS.

Operational Authority and Licensing Requirements. Non-Federal government Purchasers may operate the Deliverables within the United States under the licensing authority issued to LRS by the Federal Communications Commission (FCC), provided, however, that such operation is: (a) subject to LRS's control, (b) conducted on a non-profit, cost shared basis with costs apportioned as part of the price for such Deliverable, (c) in accordance method of operation set forth in the manual for the deliverable, available for download at <http://lrsus.com/support> and (d) limited to the term of this Agreement, the term of LRS's authority, or a term otherwise specified by LRS, whichever expires earlier. Notwithstanding the provision below entitled "No Third Party Beneficiary," users of any Deliverables acquired from Purchasers or other entities may contact LRS to determine if they may be eligible to operate under LRS's authority. Alternatively, Purchasers and users may obtain their own licensing authority; the FCC posts a list of licensing coordinators at http://wireless.fcc.gov/services/index.htm?job=licensing_3&id=industrial_business. Purchasers and eligible users of any Deliverable agree to abide by and strictly adhere to any rules, regulations and guidelines, including the FCC's rules, governing the operation of the Deliverable. Changes or modifications to any portion of any Deliverable may void the Purchaser's or user's authority to operate the Deliverable and should not be made without the express approval of LRS. Moreover, use of any portion of any Deliverable outside the United States is subject to the rules and regulations of other countries and may be prohibited. Use of any Deliverable constitutes Purchaser's and user's acceptance of and agreement to these General Terms and Conditions, including any revisions to these General Terms and Conditions that may be required to reflect changes in the regulatory or other obligations imposed upon LRS.

Governing Law and Venue. These General Terms and Conditions and any agreement relating to them shall be construed in accordance with and governed by the laws of the State of Texas (without regard to its conflicts of laws). Any dispute relating to these General Terms and Conditions and any agreement relating to them may only be heard and resolved by a court in Dallas County in the State of Texas. Purchaser consents to the personal jurisdiction of such courts over it. If any action at law or in equity is necessary to enforce or interpret any of the rights or obligations of the parties to these General Terms and Conditions, the prevailing party shall be entitled to reasonable attorneys' fees, costs, and necessary disbursements, in addition to any other relief to which it may be entitled.

No Assignment or Transfer. The rights and benefits provided under these General Terms and Conditions, as well as under any agreement that incorporates them, shall not be assigned without the express written permission of LRS. Similarly, the Deliverables may not be transferred to any other person, without the express written permission of LRS. Notwithstanding, Purchaser may temporarily loan its customers paging receivers. Purchaser may also transfer the Deliverables, as well as the rights and benefits under these General Terms and Conditions and any agreement that incorporates them, as an ancillary part of a sale of its business or substantially all of its assets. Following any assignment or transfer, Purchaser shall remain bound by all of the duties and obligations that are set forth in these General Terms and Conditions and any agree-

ment that incorporates them.

No Third Party Beneficiary. Except as otherwise expressly provided in this Agreement, these General Terms and Conditions, as well as any agreement that incorporates them, are solely for the benefit of Purchaser. Neither the customers of Purchaser, nor any other person is an intended beneficiary of these General Terms and Conditions or any agreement that incorporates them, nor shall any such person have the right to any benefit that is provided under these General Terms and Conditions or any agreement that incorporates them.

Merger. Except as otherwise specifically set forth herein, these General Terms and Conditions, and any agreement that incorporates them, supersede any oral or other representation that may have been made about these General Terms and Conditions, any agreement that incorporates them, or any of the Deliverables. These General Terms and Conditions, and any agreement that incorporates them, may not be modified or superseded, except by a written agreement or a written amendment that is signed by LRS. In the event of any inconsistency between these General Terms and Conditions or any agreement that incorporates them and any form or other document supplied by Purchaser, such as a purchase order, the terms of these General Terms and Conditions or any agreement that incorporates will prevail

Severability. In the event that any portion of these General Terms and Conditions or any agreement that incorporates them is found to be invalid or unenforceable for any reason, the remaining portions shall continue to be in full force and effect.

Fees & Payment. Purchaser agrees to pay all Service and Deliverable fees, plus any applicable taxes, in accordance with the terms and payment method set forth in this agreement. Purchaser is responsible for providing accurate billing and contact information to LRS. LRS retains the right to suspend or terminate services if fees become past due. LRS reserves the right to change Service rates by providing Customer at least 30 days' notice prior to billing.

Term & Termination. Purchaser has the option of purchasing Monthly or Annual service plans which are non-refundable and not available for proration except as required by law. Monthly agreements will auto-renew on a month-to-month basis until such time that a formal termination notice has been received by LRS. Prepaid Annual agreements will automatically renew at the end of each annual term unless Purchaser has given cancellation notice 30 days in advance of renewal term. Monthly-billed Annual agreements will auto-renew on a perpetual month-to-month basis upon completion of the initial annual term until cancellation notice is received by LRS. In the event that any agreement incorporating these General Terms and Conditions is terminated for any reason, all of the duties and obligations that the agreement and these General Terms and Conditions impose upon Purchaser shall continue in full force and effect, except any obligation to make payment for a Deliverable prior to its delivery.